

## Manufacturer and Technical Data (1)

Characteristics						
1.01	Manufacturer			<b>HELI</b>		
1.02	Model			CPD60	CPD60	CPD70
1.03	Configuration number			GB2D	GB2DLi	GB2DLi
1.04	Rated capacity	Q	kg	6000	6000	7000
1.05	Load center distance	c	mm	600	600	600
1.06	Power mode			Electric	Electric	Electric
1.07	Driving mode			Seated	Seated	Seated
1.08	Front overhang	x	mm	600	600	605
1.09	Wheelbase	y	mm	2305	2305	2305
Weight						
2.01	Total weight (with/without battery)		kg	10580/7950	9720/9170	11030/8680
2.02	Axle load (laden,front/rear)		kg	16350/1130	15280/1340	16280/1750
2.03	Axle load (unladen,front/rear)		kg	5730/4850	4750/4970	5730/5300
Tyres						
3.01	Tyre type			Solid tyre	Solid tyre	Solid tyre
3.02	Tyre size,front			8.25-15	8.25-15	8.25-15
3.03	Tyre size,rear			250-15	250-15	250-15
3.04	Wheels,number front/rear (x=driven wheels)			4/x2	4/x2	4/x2
3.05	Tread, front	b10	mm	1567	1567	1567
3.06	Tread, rear	b11	mm	1370	1370	1370
Dimensions						
4.01	Mast tilt angle (forward/backward)	$\alpha/\beta$	$^{\circ}$	6/10	6/10	6/10
4.02	Height (mast lowered)	h1	mm	2480	2480	2480
4.03	Free lifting height	h2	mm	160	160	165
4.04	Lifting height (standard)	h3	mm	3000	3000	3000
4.05	Max. height,extended (with backrest)	h4	mm	4460	4460	4460
4.06	Height of overhead guard	h6	mm	2500	2500	2491
4.07	Seat height relating to SIP (to ground)	h7	mm	1460	1460	1460
4.08	Towing coupling height	h10	mm	470	470	470
4.09	Overall length (with fork)	l1	mm	4657	4657	4662
4.10	Overall length (without fork)	l2	mm	3437	3437	3442
4.11	Overall width	b1	mm	2045	2045	2045
4.12	Fork size:thickness x width x length	s/e/l	mm	60x150x1220	60x150x1220	65x150x1220
4.13	Fork carriage,according to ISO2328			4A	4A	4A
4.14	Distance across fork-arms, Max./Min.	b5	mm	1845/300	1845/300	1845/300
4.15	Distance across fork-arms, Max./Min.	m1	mm	160	160	160
4.16	Ground clearance (center of wheelbase)	m2	mm	239	239	229
4.17	Right angle stacking aisle width for pallet 1000 x1200mm crossways	Ast	mm	4845	4845	4850
4.18	Right angle stacking aisle width for pallet 800 x1200mm lengthways	Ast	mm	5045	5045	5050
4.19	Min. outside turning radius	Wa	mm	3050	3050	3050
Performance Data						
5.01	Travel speed (laden/unladen)		km/h	15/16	15/16	15/16
5.02	Lift speed (laden/unladen)		m/s	0.35/0.46	0.35/0.46	0.32/0.46
5.03	Lowering speed (laden/unladen)		m/s	0.46/0.45	0.46/0.45	0.48/0.45
5.04	Max.drawbar pull (laden/unladen)		N	35000	35000	37000
5.05	Max.gradeability (laden)		%	19	19	18
5.06	Acceleration time(10 m)(laden/unladen)		s	4.9/5.5	4.9/5.5	4.9/5.5
Battery						
6.01	Battery voltage/Capacity		V/Ah	80/840	80/606	80/960
6.02	Battery weight (Min./Max.)		kg	2150	600	2350
6.03	Battery,according to DIN			DIN 43536A	-	DIN 43536A
Motor and controller						
7.01	Driving motor powering (S2-60min)		kW	2x17.1	2x17.1	2x17.1
7.02	Lifting motor powering (S3-15%)		kW	2x26.5	2x26.5	2x26.5
7.03	Driving motor controlling mode			MOSFET/AC	MOSFET/AC	MOSFET/AC
7.04	Lifting motor controlling mode			MOSFET/AC	MOSFET/AC	MOSFET/AC
Addition data						
8.01	Service brake/Parking brake			Hydraulic	Hydraulic	Hydraulic
8.02	Operating pressure for attachments		Mpa	14	14	14

## Manufacturer and Technical Data (2)

Characteristics						
1.01	Manufacturer			<b>HELI</b>		
1.02	Model			CPD85	CPD85	CPD100
1.03	Configuration number			GB2D	GB2DLi	GB2D
1.04	Rated capacity	Q	kg	8500	8500	10000
1.05	Load center distance	c	mm	600	600	600
1.06	Power mode			电动	电动	电动
1.07	Driving mode			座式	座式	座式
1.08	Front overhang	x	mm	650	650	660
1.09	Wheelbase	y	mm	2400	2400	2580
Weight						
2.01	Total weight (with/without battery)		kg	13952/11664	12660/12300	14780/12490
2.02	Axle load (laden,front/rear)		kg	19933/2889	18930/2245	22560/2220
2.03	Axle load (unladen,front/rear)		kg	7006/7316	6080/6620	7675/7105
Tyres						
3.01	Tyre type			Solid tyre	Solid tyre	Solid tyre
3.02	Tyre size,front			8.25-15	8.25-15	8.25-15
3.03	Tyre size,rear			250-15	250-15	250-15
3.04	Wheels,number front/rear (x=driven wheels)			4x/2	4x/2	4x/2
3.05	Tread, front	b10	mm	1686	1686	1686
3.06	Tread, rear	b11	mm	1370	1370	1370
Dimensions						
4.01	Mast tilt angle (forward/backward)	$\alpha/\beta$	$^{\circ}$	6/9	6/9	6/9
4.02	Height (mast lowered)	h1	mm	2700	2700	2950
4.03	Free lifting height	h2	mm	200	200	210
4.04	Lifting height (standard)	h3	mm	3000	3000	3000
4.05	Max. height,extended (with backrest)	h4	mm	4200	4200	4455
4.06	Height of overhead guard	h6	mm	2470	2470	2470
4.07	Seat height relating to SIP (to ground)	h7	mm	1460	1460	1460
4.08	Towing coupling height	h10	mm	467	467	467
4.09	Overall length (with fork)	l1	mm	4870	4870	5062
4.10	Overall length (without fork)	l2	mm	3650	3650	3842
4.11	Overall width	b1	mm	2165	2165	2165
4.12	Fork size:thickness x width x length	s/e/l	mm	70 x 175 x 1220	70 x 175 x 1220	80 x 175 x 1220
4.13	Fork carriage,according to ISO2328			-	-	-
4.14	Distance across fork-arms, Max./Min.	b5	mm	450-1910	450-1910	470-2100
4.15	Distance across fork-arms, Max./Min.	m1	mm	240	240	240
4.16	Ground clearance (center of wheelbase)	m2	mm	246	246	246
4.17	Right angle stacking aisle width for pallet 1000 x1200mm crossways	Ast	mm	5080	5080	5210
4.18	Right angle stacking aisle width for pallet 800 x1200mm lengthways	Ast	mm	5280	5280	5410
4.19	Min. outside turning radius	Wa	mm	3230	3230	3350
Performance Data						
5.01	Travel speed (laden/unladen)		km/h	14/15.5	14/15.5	13/15.5
5.02	Lift speed (laden/unladen)		m/s	0.300/0.395	0.300/0.395	0.255/0.350
5.03	Lowering speed (laden/unladen)		m/s	0.430/0.430	0.430/0.430	0.430/0.350
5.04	Max.drawbar pull (laden/unladen)		N	35000	35000	45000
5.05	Max.gradeability (laden)		%	18	18	15
5.06	Acceleration time(10 m)(laden/unladen)		s	5.38/5.84	5.38/5.84	5.62/6.31
Battery						
6.01	Battery voltage/Capacity		V/Ah	80/960	80/808	80/960
6.02	Battery weight (Min./Max.)		kg	2288	800	2288
6.03	Battery,according to DIN			DIN 43536A	-	DIN 43536A
Motor and controller						
7.01	Driving motor powering (S2-60min)		kW	17.1 x 2	17.1 x 2	17.1 x 2
7.02	Lifting motor powering (S3-15%)		kW	26.5 x 2	26.5 x 2	26.5 x 2
7.03	Driving motor controlling mode			MOSFET/AC	MOSFET/AC	MOSFET/AC
7.04	Lifting motor controlling mode			MOSFET/AC	MOSFET/AC	MOSFET/AC
Addition data						
8.01	Service brake/Parking brake			液力	液力	液力
8.02	Operating pressure for attachments		Mpa	14	14	14

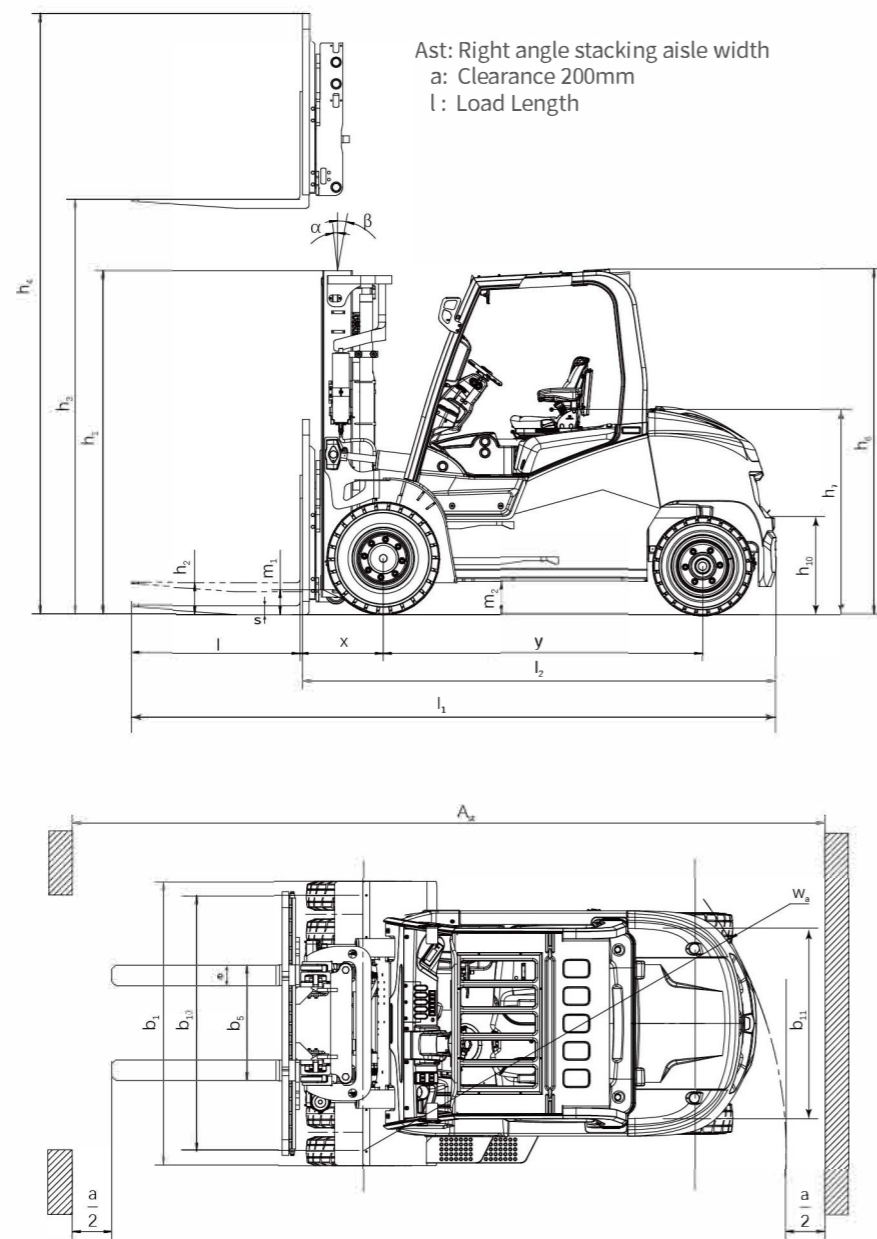

Load curve

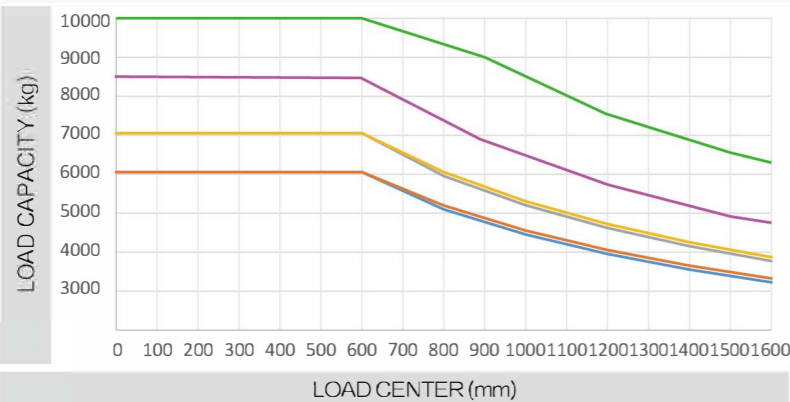

- CPD60-GB2D
- CPD60-GB2DLi
- CPD70-GB2D
- CPD70-GB2DLi
- CPD85-GB2D(Li)
- CPD100-GB2D(Li)

**Note:** The vertical axis stands for load capacity and the horizontal axis stands for load center which is calculated from the front surface of the forks to the gravity of the standard load. The standard load means a cubic with 1000mm edge length. When mast is tilted forward, using non-standard forks or loading large goods, the load capacity will be reduced. The load capacity of standard mast at different load center can be known from this load chart.

## Operating Cost Comparison: Lithium battery forklift **vs.** Lead-acid battery forklift **vs.** IC forklift

The advantages of HELI lithium battery forklift trucks are more prominent in the life cycle cost. Compared with internal combustion forklift truck, lithium battery forklift truck has the advantages of no noise, no pollution, small vibration and simple operation. Compared with the lead-acid battery forklift truck, lithium battery forklift has the characteristics of fast charging and charging at any time, which is more suitable for multi shift operation. Besides, HELI lithium battery forklift is maintenance free, high power conversion efficiency, and economical overall operation cost.

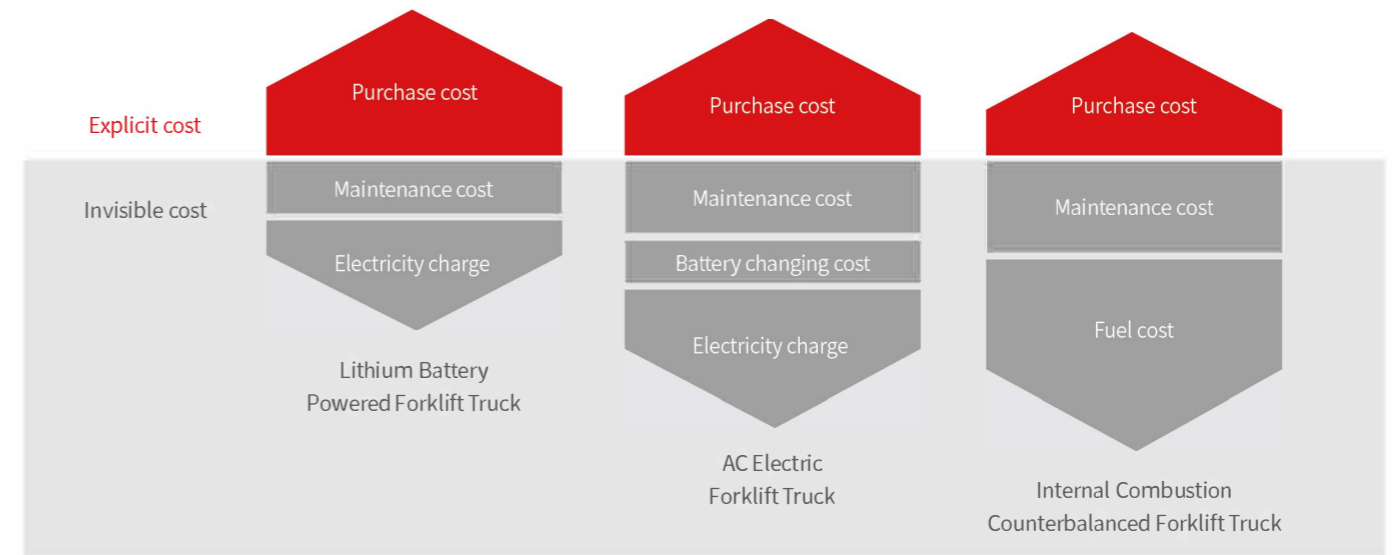

### Lithium Battery Advantages

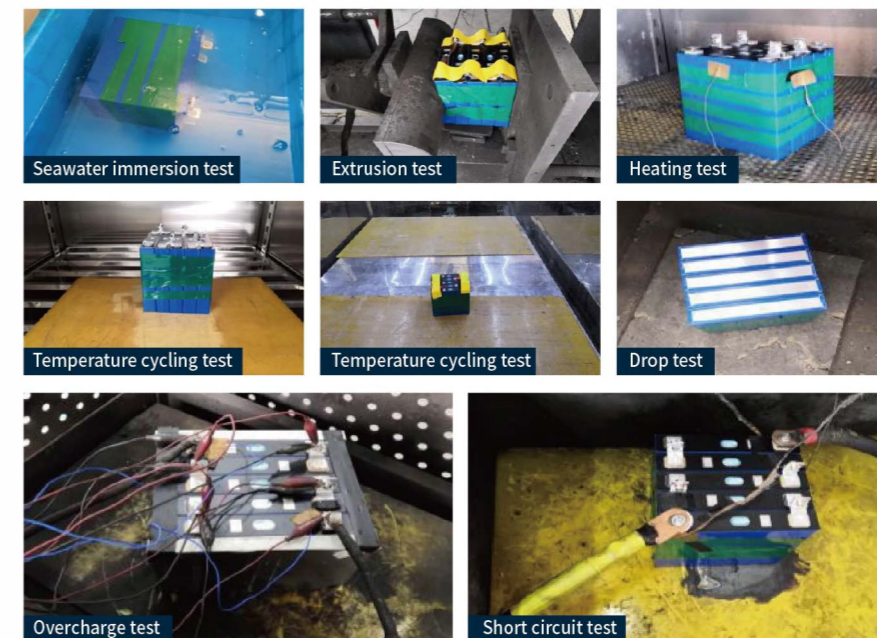

- ✓ The truck selects mature and economical square iron phosphate lithium battery core and module used by large numbers of commercial vehicles;
- ✓ The module adopts aluminum alloy plate frame, which is firm, light in weight and has good heat dissipation effect;
- ✓ Fast charging: fast charging makes truck gapless operation possible, and it can be filled in 2 hours;
- ✓ High efficiency and safety: The charging and discharging efficiency is up to 98%, and temperature of thermal runaway is over 600 °C;
- ✓ Low temperature adaptability: Standard configuration of heating function ensures normal operation of low temperature environment;
- ✓ Long service life: the normal charging and discharging cycles is more than 4000 times or 5 years, and capacity retention rate is more than 75%;
- ✓ Maintenance free: the battery does not need manual maintenance and does not need to add distilled water electrolyte;
- ✓ Green and clean: no pollution and zero emission.

## G3 6-7t Wide View Standard Mast

Mast model	Max.lifting height (mm)	Load capacity (lode center 600mm) (kg)				Height (mast lowered) (mm)		Free lift (with backrest) (mm)		Service weight (kg)				Mast tilt angle $\alpha/\beta$ (°)
		CPD60-GB2D	CPD60-GB2DLI	CPD70-GB2D	CPD70-GB2DLI	CPD60-GB2D/GB2DLI	CPD70-GB2D/GB2DLI	CPD60-GB2D/GB2DLI	CPD70-GB2D/GB2DLI	CPD60-GB2D	CPD60-GB2DLI	CPD70-GB2D	CPD70-GB2DLI	
M220	2200	6000	6000	7000	7000	2080	165	10470	9600	10920	10210	6/10		
M250	2500	6000	6000	7000	7000	2230	165	10510	9640	10960	10250	6/10		
M270	2700	6000	6000	7000	7000	2330	165	10540	9670	10990	10280	6/10		
M300	3000	6000	6000	7000	7000	2480	165	10580	9720	11030	10330	6/10		
M330	3300	6000	6000	7000	7000	2630	165	10610	9750	11060	10360	6/10		
M350	3500	6000	6000	7000	7000	2730	165	10640	9780	11090	10390	6/10		
M400	4000	6000	6000	7000	7000	3030	165	10820	9960	11270	10570	6/10		
M425	4250	6000	6000	7000	7000	3155	165	10850	9990	11300	10600	6/10		
M450	4500	6000	6000	7000	7000	3280	165	10890	10020	11340	10630	6/10		
M475	4750	6000	6000	7000	7000	3405	165	10930	10060	11380	10670	6/5		
M500	5000	6000	6000	7000	7000	3530	165	10960	10090	11410	10700	6/5		
M550	5500	5700	5900	6600	6800	3830	165	11140	10270	11590	10880	6/5		
M600	6000	5400	5600	6400	6600	4080	165	11200	10330	11650	10940	6/5		

## G3 8.5-10t Wide View Standard Mast

Mast model	Max.lifting height (mm)	Load capacity (lode center 600mm) (kg)		Height (mast lowered) (mm)		Service weight (kg)				Mast tilt angle $\alpha/\beta$ (°)
		CPD85	CPD100	CPD85	CPD100	CPD85-GB2D	CPD85-GB2DLI	CPD100-GB2D	CPD100-GB2DLI	
M250	2500	8500	10000	2450	2700	13272	11979	14659	13941	6/9
M270	2700	8500	10000	2550	2800	13327	12034	14699	13981	6/9
M300	3000	8500	10000	2700	2950	13952	12659	14780	14062	6/9
M330	3300	8500	10000	2800	3100	14053	12760	14828	14110	6/9
M350	3500	8500	10000	2950	3200	14198	12905	14873	14155	6/9
M375	3750	8500	10000	3075	3325	14318	13025	14923	14205	6/9
M400	4000	8500	10000	3250	3500	14493	13200	15063	14345	6/9
M425	4250	8500	10000	3375	3625	14648	13355	15118	14400	6/9
M450	4500	8500	10000	3500	3750	14768	13475	15168	14450	6/9
M475	4750	7750	10000	3625	3875	14913	13620	15225	14507	6/6
M500	5000	7750	10000	3750	4000	15028	13735	15280	14562	6/6
M550	5500	7400	9000	4050	4300	15350	14057	15581	14863	6/6
M600	6000	7000	8000	4300	4550	15553	14260	15631	14913	6/6

## G3 6-7t Wide View Full Free 2-Stage Mast

Mast model	Max.lifting height (mm)	Load capacity (lode center 600mm) (kg)				Height (mast lowered) (mm)		Free lift (with backrest) (mm)		Service weight (kg)				Mast tilt angle $\alpha/\beta$ (°)
		CPD60-GB2D	CPD60-GB2DLI	CPD70-GB2D	CPD70-GB2DLI	CPD60-GB2D/GB2DLI	CPD70-GB2D/GB2DLI	CPD60-GB2D/GB2DLI	CPD70-GB2D/GB2DLI	CPD60-GB2D	CPD60-GB2DLI	CPD70-GB2D	CPD70-GB2DLI	
ZM220	2200	6000	6000	7000	7000	2060	710	10570	9700	11050	10340	6/10		
ZM250	2500	6000	6000	7000	7000	2210	860	10615	9745	11095	10385	6/10		
ZM270	2700	6000	6000	7000	7000	2310	960	10650	9780	11130	10420	6/10		
ZM300	3000	6000	6000	7000	7000	2460	1110	10695	9835	11175	10475	6/10		
ZM330	3300	6000	6000	7000	7000	2610	1260	10730	9870	11210	10510	6/10		
ZM350	3500	6000	6000	7000	7000	2710	1360	10765	9905	11245	10545	6/10		
ZM400	4000	6000	6000	7000	7000	3010	1660	10950	10090	11430	10730	6/10		
ZM425	4250	6000	6000	7000	7000	3135	1785	10985	10125	11465	10765	6/10		
ZM450	4500	6000	6000	7000	7000	3260	1910	11030	10160	11510	10800	6/10		
ZM475	4750	6000	6000	7000	7000	3385	2035	11075	10205	11555	10845	6/5		
ZM500	5000	6000	6000	7000	7000	3510	2160	11110	10240	11590	10880	6/5		
ZM550	5500	5700	5900	6600	6800	3810	2460	11295	10425	11775	11065	6/5		
ZM600	6000	5400	5600	6400	6600	4060	2710	11360	10490	11840	11130	6/5		

注: 不带挡货架自由起升高度6t: +340mm,7t: +180mm

## G3 8.5-10t Wide View Full Free 2-Stage Mast

Mast model	Max.lifting height (mm)	Load capacity (lode center 600mm) (kg)		Height (mast lowered) (mm)		Free lift (with backrest) (mm)		Service weight (kg)				Mast tilt angle $\alpha/\beta$ (°)
		CPD85	CPD100	CPD85	CPD100	CPD85	CPD100	CPD85-GB2D	CPD85-GB2DLI	CPD100-GB2D	CPD100-GB2DLI	
ZM250	2500	8500	10000	2450	2700	1245	1220	13999	12706	14659	13941	6/9
ZM270	2700	8500	10000	2550	2800	1345	1290	14025	12732	14699	13981	6/9
ZM300	3000	8500	10000	2700	2950	1495	1440	14067	12774	14739	14021	6/9
ZM330	3300	8500	10000	2800	3100	1645	1590	14108	12815	14819	14101	6/9
ZM350	3500	8500	10000	2950	3200	1745	1690	14136	12843	14854	14136	6/9
ZM375	3750	8300	10000	3075	3325	1870	1815	14171	12878	14904	14186	6/9
ZM400	4000	8300	10000	3250	3500	2045	1990	14308	13015	15044	14326	6/9
ZM425	4250	8000	10000	3375	3625	2170	2115	14342	13049	15099	14381	6/9
ZM450	4500	8000	10000	3500	3750	2295	2240	14377	13084	15149	14431	6/9
ZM475	4750	8000	10000	3625	3875	2420	2365	14412	13119	15209	14491	6/6
ZM500	5000	7800	10000	3750	4000	2545	2490	14417	13124	15261	14543	6/6
ZM550	5500	7500	9000	4050	4300	2845	2790	14619	13326	15561	14843	6/6
ZM600	6000	7200	8000	4300	4550	3095	3040	14688	13395	15609	14891	6/6

## G3 6-7t Wide View Full Free 3-Stage Mast

Mast model	Max.lifting height (mm)	Load capacity (lode center 600mm) (kg)				Height (mast lowered) (mm)		Free lift (with backrest) (mm)		Service weight (kg)				Mast tilt angle $\alpha/\beta$ (°)
		CPD60-GB2D	CPD60-GB2DLI	CPD70-GB2D	CPD70-GB2DLI	CPD60-GB2D/GB2DLI	CPD70-GB2D/GB2DLI	CPD60-GB2D/GB2DLI	CPD70-GB2D/GB2DLI	CPD60-GB2D	CPD60-GB2DLI	CPD70-GB2D	CPD70-GB2DLI	
ZSM360	3600	5600	5750	6200	6350	2335	920	11080	9890	11530	10500	6/5		
ZSM400	4000	5600	5750	6200	6350	2460	1045	11140	9950	11590	10560	6/5		
ZSM435	4350	5600	5750	6200	6350	2585	1170	11190	10000	11640	10610	6/5		
ZSM450	4500	5600	5750	6200	6350	2635	1220	11220	10030	11670	10640	6/5		
ZSM480	4800	5600	5750	6200	6350	2740	1325	11270	10080	11720	10690	6/5		
ZSM500	5000	5600	5750	6200	6350	2805	1390	11300	10110	11750	10720	6/5		
ZSM540	5400	5300	5450	6000	6150	2940	1525	11360	10170	11810	10780	6/5		
ZSM600	6000	5000	5150	5600	5750	3135	1720	11450	10260	11900	10870	6/5		
ZSM650	6500	4500	4650	5000	5150	3405	1990	11530	10340	11980	10950	6/5		
ZSM700	7000	4000	4150	4500	4650	3510	2095	11610	10420	12060	11030	6/5		

注: 不带挡货架自由起升高度6t: +340mm,7t: +180mm

## G3 8.5-10t Wide View Full Free 3-Stage Mast

Mast model	Max.lifting height (mm)	Load capacity (lode center 600mm) (kg)		Height (mast lowered) (mm)		Free lift (with backrest) (mm)		Service weight (kg)				Mast tilt angle $\alpha/\beta$ (°)
		CPD85	CPD100	CPD85	CPD100	CPD85	CPD100	CPD85-GB2D	CPD85-GB2DLI	CPD100-GB2D	CPD100-GB2DLI	
ZSM360	3600	7500	8000	2450	2570	1235	1180	14593	13300	15516	14798	6/9
ZSM400	4000	7500	8000	2575	2700	1360	1310	14664	13371	15608	14890	6/9
ZSM435	4350	7500	8000	2700	2820	1485	1430	14738	13445	15688	14970	6/9
ZSM450	4500	7500	8000	2750	2870	1535	1480	14765	13472	15728	15010	6/9
ZSM480	4800	7500	7500	2850	2970	1635	1580	14826	13533	15796	15078	6/6
ZSM500	5000	7500	7500	2950	3035	1735	1645	14882	13589	15842	15124	6/6
ZSM540	5400	7000	7000	3075	3225	1860	1835	14956	13663	15976	15258	6/6
ZSM600	6000	6400	6000	3375	3425	2160	2035	15127	13834	16116	15398	6/6

