

Intelligent security

Intelligent control and protection improve the safety of drivers.

- Dual core controller
- OPS protection
(standard driving OPS / optional hydraulic OPS)
- Hydraulic burst protection, forward tilting self-locking protection
- Electrical multiple protection
(short circuit protection, overheat protection, low power protection, sequence protection)
- Parking safety reminder
- Reminder through slow sliding on ramp
- Turning automatic deceleration (optional)



- Pump, pump motor, controller and other main electrical components are located on the counterweight, which is convenient for maintenance.
- Battery side pulling model can be chosen for more efficient replacement and maintenance.
- Flexible battery charging mode (can be charged with the truck or replaced)



Convenient maintenance

More convenient maintenance operation improves the maintenance efficiency of after-sale services.

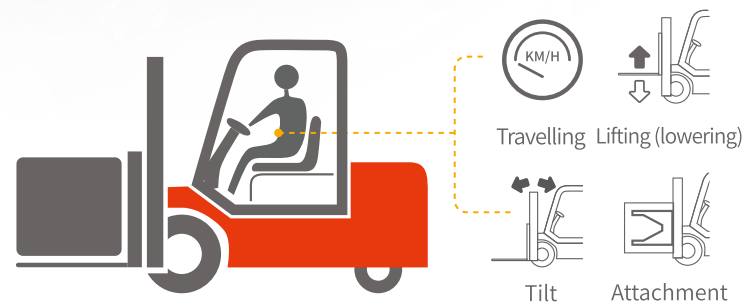
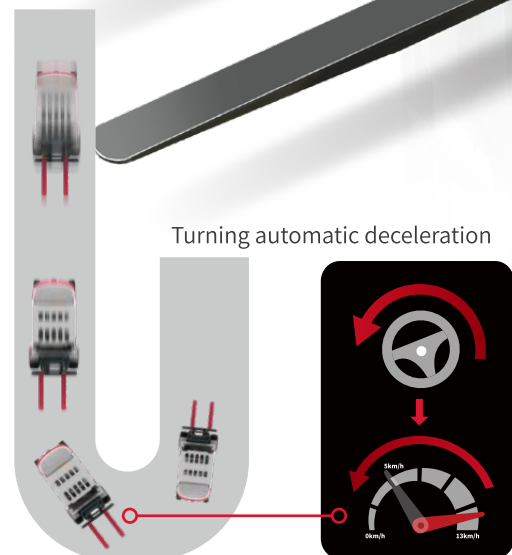

 **Driver Presence Sensing System** **Unmanned self-locking intelligent protection**

Manufacturer and Technical Data(Tabulation 1)

Characteristics		HELI					
1.01	Manufacturer	HELI					
1.02	Model	CPD15		CPD18	CPD15	CPD18	CPD20
1.03	Configuration number	A3LiH4-M*		A7LiH4-S		A7XLiH4-S	
1.04	Rated capacity	Q	kg	1500	1800	1500	1800
1.05	Load center distance	c	mm	500			
1.06	Power mode	Lithium battery					
1.07	Driving mode	Seated					
1.08	Front overhang	x	mm	409		414	
1.09	Wheelbase	y	mm	1475		1475	
Weight							
2.01	Total weight (with/without battery)		kg	2855/2675	2970/2790	2835/2672	2950/2787
2.02	Axle load (laden,front/rear)		kg	3719/636	4203/567	3711/624	4196/555
2.03	Axle load (unladen, front/rear)		kg	1294/1561	1293/1677	1287/1548	1286/1664
Tyres							
3.01	Tyre type	Pneumatic tyre			Pneumatic tyre		
3.02	Tyre size,front	6.50-10-10PR			6.50-10-10PR		6.50-10-12PR
3.03	Tyre size,rear	16×6-8-10PR			16×6-8-10PR		
3.04	Wheels, number front/rear (x=driven wheels)	2/2			2/2		
3.05	Tread, front	b10	mm	934			
3.06	Tread, rear	b11	mm	920			
Dimensions							
4.01	Mast tilt angle (forward/backward)	α/β	°	6/8		6/8	
4.02	Height (mast lowered)	h1	mm	1995			
4.03	Free lifting height	h2	mm	155			
4.04	Lifting height (standard)	h3	mm	3000		3000	
4.05	Max. height, extended (with backrest)	h4	mm	4014			
4.06	Height of overhead guard	h6	mm	2130			
4.07	Seat height relating to SIP (to ground)	h7	mm	1125		1125	
4.08	Towing coupling height	h10	mm	250			
4.09	Overall length (with fork)	l1	mm	3120		3125	
4.10	Overall length (without fork)	l2	mm	2200		2205	
4.11	Overall width	b1	mm	1120			
4.12	Fork carriage, according to ISO2328	2A					
4.13	Fork size:thickness x width x length	s/e/l	mm	35×100×920		40×100×920	
4.14	Fork adjustable range(external at the fork),Max./Min.	b5	mm	960/200		960/200	
4.15	Ground clearance (at mast)	m1	mm	100			
4.16	Ground clearance (center of wheelbase)	m2	mm	95			
4.17	Right angle stacking aisle width for pallet 1000 x1200mm crossways	Ast	mm	3575		3580	
4.18	Right angle stacking aisle width for pallet 800 x1200mm lengthways	Ast	mm	3770		3775	
4.19	Min. outside turning radius	Wa	mm	1920			
Performance data							
5.01	Travel speed (laden/unladen)		km/h	14.5/15		12/13	
5.02	Lift speed (laden/unladen)		m/s	0.320/0.440	0.290/0.440	0.270/0.400	0.260/0.400
5.03	Lowering speed (laden/unladen)		m/s	0.400/0.400			
5.04	Max.drawbar pull (laden)		N	10200/9700	10200/9800	10200/9700	11000/10700
5.05	Max.gradeability (laden/unladen)		%	17/27	15/26	15/22	15/25
5.06	Acceleration time(10 m)(laden/unladen)		s	5.5/5.2	5.6/5.3	6.0/5.7	5.6/5.2
Battery							
6.01	Battery voltage/Capacity		V/Ah	80/150		80/125	
6.02	Battery weight		kg	180		163	
Motor and controller							
7.01	Driving motor powering (S2-60min)		kW	8		8	
7.02	Lifting motor powering (S3-15%)		kW	10.6		10.6	
7.03	Driving motor controlling mode	MOSFET/AC					
7.04	Lifting motor controlling mode	MOSFET/AC					
Addition data							
8.01	Service brake/Parking brake	Hydraulic/Mechanical					
8.02	Operating pressure for attachments		Mpa	16			

Manufacturer and Technical Data(Tabulation 2)

Characteristics		HELI					
1.01	Manufacturer	HELI					
1.02	Model	CPD20		CPD25	CPD20	CPD25	CPD25
1.03	Configuration number	A3LiH4-M*		A3LiPH4-M		A7LiH4-S	
1.04	Rated capacity	Q	kg	2000	2500	2000	2500
1.05	Load center distance	c	mm	500			
1.06	Power mode	Lithium battery					
1.07	Driving mode	Seated					
1.08	Front overhang	x	mm	460			
1.09	Wheelbase	y	mm	1660			
Weight							
2.01	Total weight (with/without battery)		kg	3585/3395	3925/3735	3680/3490	4020/3830
2.02	Axle load (laden,front/rear)		kg	4970/615	5790/635	5030/650	5850/670
2.03	Axle load (unladen, front/rear)		kg	1750/1835	1780/2145	1810/1870	1840/2180
Tyres							
3.01	Tyre type	Pneumatic tyre					
3.02	Tyre size,front	7.00-12-14PR					
3.03	Tyre size,rear	18×7-8-14PR					
3.04	Wheels, number front/rear (x=driven wheels)	2/2					
3.05	Tread, front	b10	mm	970			
3.06	Tread, rear	b11	mm	960			
Dimensions							
4.01	Mast tilt angle (forward/backward)	α/β	°	6/10			
4.02	Height (mast lowered)	h1	mm	2000			
4.03	Free lifting height	h2	mm	165			
4.04	Lifting height (standard)	h3	mm	3000			
4.05	Max. height, extended (with backrest)	h4	mm	4020			
4.06	Height of overhead guard	h6	mm	2170			
4.07	Seat height relating to SIP (to ground)	h7	mm	1154			
4.08	Towing coupling height	h10	mm	300			
4.09	Overall length (with fork)	l1	mm	3354	3504	3354	3504
4.10	Overall length (without fork)	l2	mm	2434			
4.11	Overall width	b1	mm	1180			
4.12	Fork carriage, according to ISO2328	2A					
4.13	Fork size:thickness x width x length	s/e/l	mm	40×122×920	40×122×1070	40×122×920	40×122×1070
4.14	Fork adjustable range(external at the fork),Max./Min.	b5	mm	1030/250			
4.15	Ground clearance (at mast)	m1	mm	100			
4.16	Ground clearance (center of wheelbase)	m2	mm	125			
4.17	Right angle stacking aisle width for pallet 1000 x1200mm crossways	Ast	mm	3753			
4.18	Right angle stacking aisle width for pallet 800 x1200mm lengthways	Ast	mm	3953			
4.19	Min. outside turning radius	Wa	mm	2140			
Performance data							
5.01	Travel speed (laden/unladen)		km/h	14.5/15		14.5/15	
5.02	Lift speed (laden/unladen)		m/s	0.320/0.440	0.290/0.440	0.320/0.440	0.290/0.440
5.03	Lowering speed (laden/unladen)		m/s	0.360/0.460			
5.04	Max.drawbar pull (laden)		N	13600/13000	14000/13300	13600/13000	14000/13300
5.05	Max.gradeability (laden/unladen)		%	17/26	15/25	17/26	15/25
5.06	Acceleration time(10 m)(laden/unladen)		s	5.9/5.0	6.1/5.0	5.9/5.0	6.1/5.0
Battery							
6.01	Battery voltage/Capacity		V/Ah	80/202		80/202	
6.02	Battery weight		kg	190		190	
Motor and controller							
7.01	Driving motor powering (S2-60min)		kW	11			
7.02	Lifting motor powering (S3-15%)		kW	12			
7.03	Driving motor controlling mode	MOSFET/AC					
7.04	Lifting motor controlling mode	MOSFET/AC					
Addition data							
8.01	Service brake/Parking brake	Hydraulic/Mechanical					
8.02	Operating pressure for attachments		Mpa	16			

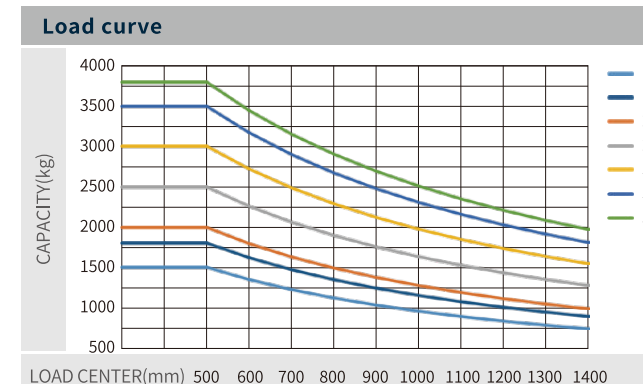
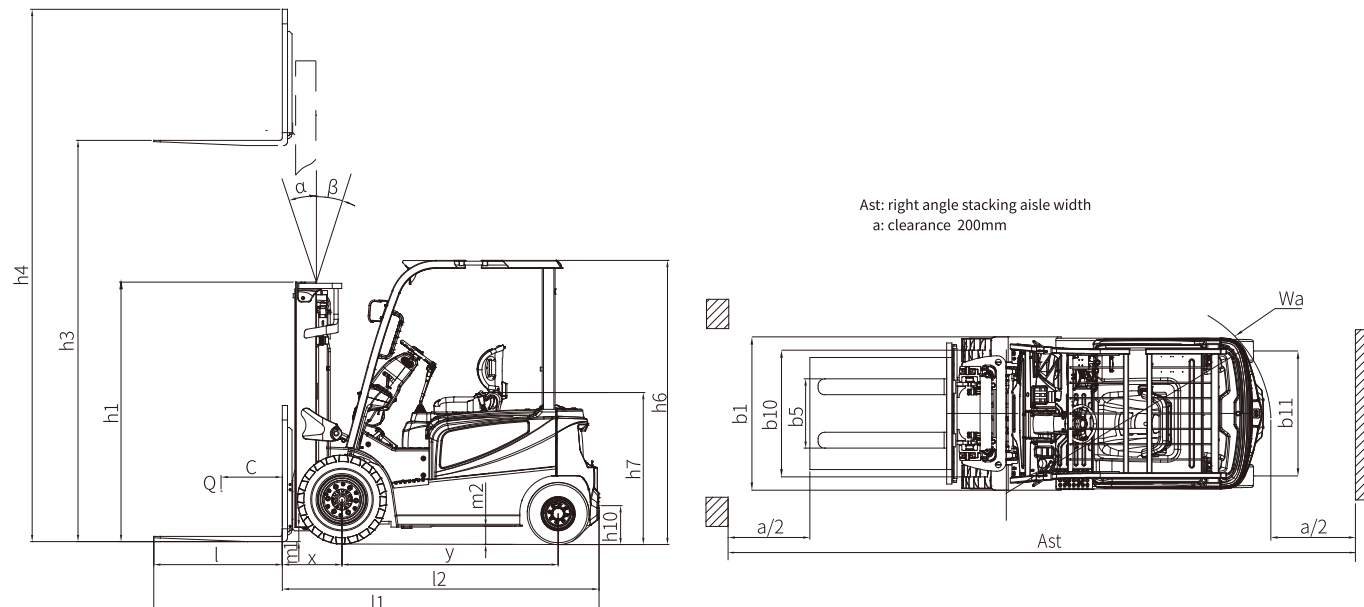

Note:
 The vertical axis stands for load capacity and the horizontal axis stands for load center which is calculated from the front surface of the forks to the gravity of the standard load. the standard load means a cubic with 1000mm edge length. When mast is tilted forward, using non-standard forks or loading large goods, the load capacity will be reduced. The load capacity of standard mast at different load center can be known from this load chart.

Manufacturer and Technical Data (Tabulation 3)									
Characteristics									
1.01	Manufacturer	HELI							
1.02	Model	CPD30	CPD35	CPD30	CPD35	CPD30	CPD35	CPD38	
1.03	Configuration number	A3LiH4-M*		A3LiPH4-M		A7LiH4-S		A7LiH4-S	
1.04	Rated capacity	Q	kg	3000	3500	3000	3500	3000	3800
1.05	Load center distance	c	mm	500					
1.06	Power mode	Lithium battery							
1.07	Driving mode	Seated							
1.08	Front overhang	x	mm	477	482	477	482	477	482
1.09	Wheelbase	y	mm	1750					
Weight									
2.01	Total weight (with/without battery)	kg	4550/4310	4860/4620	4670/4430	4980/4740	4500/4290	4810/4600	5240/5000
2.02	Axle load (laden, front/rear)	kg	6750/800	7630/730	6810/860	7690/790	6710/790	7590/720	8150/890
2.03	Axle load (unladen, front/rear)	kg	2050/2500	2110/2750	2110/2560	2170/2810	2010/2490	2070/2740	2220/3020
Tyres									
3.01	Tyre type	Pneumatic tyre(front tyre)/Solid tyre(rear tyre)							
3.02	Tyre size, front	28x9-15-14PR							28x12.5-15-24PR
3.03	Tyre size, rear	18x7-8							200/50-10
3.04	Wheels, number front/rear (x=driven wheels)	2/2							
3.05	Tread, front	b10	mm	1000					
3.06	Tread, rear	b11	mm	970					
Dimensions									
4.01	Mast tilt angle (forward/backward)	α/β	°	6/10					
4.02	Height (mast lowered)	h1	mm	2070	2120	2070	2120	2070	2120
4.03	Free lifting height	h2	mm	155		155			160
4.04	Lifting height (standard)	h3	mm	3000					
4.05	Max. height, extended (with backrest)	h4	mm	4217					
4.06	Height of overhead guard	h6	mm	2180					
4.07	Seat height relating to SIP (to ground)	h7	mm	1164					
4.08	Towing coupling height	h10	mm	310					
4.09	Overall length (with fork)	l1	mm	3637	3642	3637	3642	3637	3642
4.10	Overall length (without fork)	l2	mm	2567	2572	2567	2572	2567	2572
4.11	Overall width	b1	mm	1260					
4.12	Fork carriage, according to ISO2328	3A							
4.13	Fork size: thickness x width x length	s/e/l	mm	45x125x1070	50x125x1070	45x125x1070	50x125x1070	45x125x1070	50x125x1070
4.14	Fork adjustable range (external at the fork), Max./Min.	b5	mm	1060/250					
4.15	Ground clearance (at mast)	m1	mm	110					
4.16	Ground clearance (center of wheelbase)	m2	mm	135					
4.17	Right angle stacking aisle width for pallet 1000x1200mm crossways	Ast	mm	3912	3917	3912	3917	3912	3917
4.18	Right angle stacking aisle width for pallet 800x1200mm lengthways	Ast	mm	4115	4117	4115	4117	4115	4117
4.19	Min. outside turning radius	Wa	mm	2235					
Performance data									
5.01	Travel speed (laden/unladen)	km/h	14.5/15	14.5/15	14.5/15	12/13	12/13	12/13	12/13
5.02	Lift speed (laden/unladen)	m/s	0.320/0.440	0.290/0.440	0.320/0.440	0.290/0.440	0.290/0.400	0.270/0.400	0.270/0.400
5.03	Lowering speed (laden/unladen)	m/s	0.400/0.400						
5.04	Max. drawbar pull (laden)	N	16300/15800	17000/16600	16300/15800	17000/16600	16300/16000	16900/15900	16800/16200
5.05	Max. gradeability (laden/unladen)	%	17/26	15/23	17/26	15/23	15/25	15/22	15/20
5.06	Acceleration time (10 m) (laden/unladen)	s	5.7/5.1	6.1/5.2	5.7/5.1	6.1/5.2	5.8/5.3	6.3/5.4	6.2/5.2
Battery									
6.01	Battery voltage/Capacity	V/Ah	80/250	80/250	80/250	80/202	80/250	80/250	80/250
6.02	Battery weight	kg	240	240	240	210	240	240	240
Motor and controller									
7.01	Driving motor powering (S2-60min)	kW	15						
7.02	Lifting motor powering (S3-15%)	kW	16						
7.03	Driving motor controlling mode		MOSFET/AC						
7.04	Lifting motor controlling mode		MOSFET/AC						
Addition data									
8.01	Service brake/Parking brake		Hydraulic/Mechanical						
8.02	Operating pressure for attachments	Mpa	16						

Note: P refers to the battery side pulling.

Lithium battery																			
Battery brand	HELI					CATL													
Voltage/Capacity	80V/125Ah	80V/150Ah	80V/202Ah	80V/250Ah	80V/280Ah	80V/404Ah	80V/560Ah	80V/125Ah	80V/150Ah	80V/173Ah	80V/202Ah	80V/228Ah	80V/271Ah	80V/302Ah	80V/346Ah	80V/404Ah	80V/456Ah	80V/542Ah	80V/604Ah
1.5-1.8t S	●	○	○	○	○	○	○	○	○	○	○	○	○	○	○	○	○	○	○
1.5-1.8t M	○	○	○	○	○	○	○	○	○	○	○	○	○	○	○	○	○	○	○
2t(X) S	○	○	○	○	○	○	○	○	○	○	○	○	○	○	○	○	○	○	○
2-2.5t S	○	○	○	○	○	○	○	○	○	○	○	○	○	○	○	○	○	○	○
2-2.5t M	○	○	○	○	○	○	○	○	○	○	○	○	○	○	○	○	○	○	○
3-3.5t S	○	○	○	○	○	○	○	○	○	○	○	○	○	○	○	○	○	○	○
3-3.5t M	○	○	○	○	○	○	○	○	○	○	○	○	○	○	○	○	○	○	○
3.8t S	○	○	○	○	○	○	○	○	○	○	○	○	○	○	○	○	○	○	○
Heating at low Temperature	○	○	○	○	○	○	○	○	○	○	○	○	○	○	○	○	○	○	○

Note: ● standard; ○ optional; — non-configurable.

Charger	
Model	D80V100ALI-438
Wiring type	Three-phase four-wiring type
Power of charger	10
Air switch model of Upper level power	32
Input voltage range	380±15%
Input current	< 20A
Output current	5-100
Protection level	For indoor use
Working ambient temperature	-20~+45
Plugs and sockets	REMA320
Charger	Full charging time=required charging capacity/charging current+0.2h For example: the battery capacity is 80V/250Ah, and the discharging state is alarmed by instrument, The charger is 100A, thus the full charging time is 250*0.9/100+0.2≈2.45h

1.5t/1.8t/2t(E) Mast parameters																
Mast type	Mast model	Max. lifting height (mm)	Load capacity (lode center 500mm)(kg)			Height (mast lowered) (mm)		Free lift (with backrest) (mm)		Service weight (kg)					Mast tilt angle α/β (°)	
			1.5t	1.8t	2t(E)	1.5-1.8t	2t(E)	1.5t-S	1.5t-M	1.8t-S	1.8t-M	2t(E)	1.5-1.8t	2t(E)		
2-stage standard Mast	M200	2000	1500	1800	2000	1495	1495	155	155	2771	2791	2886	2905	3036	6/8	6/8
	M250	2500	1500	1800	2000	1745	1745	155	155	2803	2823	2918	2938	3058	6/8	6/8
	M300	3000	1500	1800	2000	1995	1995	155	155	2835	2855	2950	2970	3100	6/8	6/8
	M330	3300	1500	1800	2000	2145	2145	155	155	2854	2874	2969	2989	3119	6/8	6/8
	M350	3500	1500	1800	2000	2245	2245	155	155	2867	2887	2982	3002	3132	6/8	6/6
	M370	3700	1500	1800	2000	2345	2345	155	155	2880	2900	2995	3015	3145	6/6	6/6
	M400	4000	1500	1800	2000	2545	2545	155	155	2928	2948	3043	3063	3193	6/6	6/6
	M425	4250	1500	1800	1950	2670	2670	155	155	2945	2965	3060	3080	3210	6/6	6/6
	M450	4500	1450	1750	1750	2795	2795	155	155	2961	2981	3076	3096	3226	6/6	6/6
	M500	5000	1200	1400	1500	3045	3045	155	155	2993	3013	3108	3128	3258	6/6	6/6
	M550	5500	1000	1100	1300	3345	3345	155	155	3055	3075	3170	3190	3320	3/6	3/6
	M600	6000	800	900	900	3595	3595	155	155	3087	3107	3202	3222	3352	3/6	3/6
2-stage full free mast	ZM200	2000	1500	1800	2000	1495	1495	485	485	2820	2840	2935	2955	3085	6/8	6/8
	ZM250	2500	1500	1800	2000	1745	1745	735	735	2852	2872	2967	2987	3117	6/8	6/8
	ZM300	3000	1500	1800	2000	1995	1995	985	985	2886	2906	3001	3021	3151	6/8	6/8
	ZM330	3300	1500	1800	2000	2145	2145	1135	1135	2908	2928	3023	3042	3173	6/8	6/8
	ZM350	3500	1500	1800	2000	2245	2245	1235	1235	2923	2943	3038	3058	3188	6/8	6/8
	ZM370	3700	1500	1800	2000	2345	2345	1335	1335	2935	2955	3050	3070	3200	6/6	6/6
	ZM400	4000	1500	1800	2000	2545	2545	1535	1535	2983	3002	3098	3118	3248	6/6	6/6
	ZM425	4250	1500	1800	1950	2670	2670	1660	1660	3002	3022	3117	3137	3267	6/6	6/6
	ZM450	4500	1450	1750	1750	2795	2795	1785	1785	3021	3041	3136	3156	3286	6/6	6/6
	ZM500	5000	1200	1400	1500	3045	3045	2035	2035	3055	3075	3170	3190	3320	3/6	3/6
	ZM550	5500	1000	1100	1300	3345	3345	2335	2335	3116	3136	3231	3251	3381	3/6	3/6
	ZM600	6000	800	900	900	3595	3595	2585	2585	3150	3170	3265	3285	3415	3/6	3/6
3 stage full free mast	ZSM360	3600	1500	1800	2000	1790	1790	785	785	2934	2954	3049	3069	3199	6/6	6/6
	ZSM400	4000	1500	1800	2000	1925	1925	920	920	2958	2978	3073	3093	3223	6/6	6/6
	ZSM435	4350	1450	1700	1850	2040	2040	1035	1035	2983	3003	3098	3118	3248	6/6	6/6
	ZSM450	4500	1450	1700	1750	2090	2090	1085	1085	2994	3014	3109	3129	3259	6/6	6/6
	ZSM470	4700	1450	1650	1650	2160	2160	1155	1155	3010	3030	3125	3145	3275	6/6	6/6
	ZSM480	4800	1350	1550	1650	2190	2190	1185	1185	3017	3037	3132	3152	3282	6/6	6/6
	ZSM500	5000	1300	1400	1500	2290	2290	1285	1285	3038	3058	3153	3173	3303	6/6	6/6
	ZSM540	5400	1000	1100	1300	2415	2415	1410	1410	3064	3084	3179	3199	3329	3/6	3/6
	ZSM600	6000	800	900	900											

3t/3.5t/3.8t Mast parameters

Mast type	Mast model	Max.lifting height (mm)	Load capacity (lode center 500mm)(kg)			Height (mast lowered) (mm)			Free lift (with backrest) (mm)			Service weight (kg)						Mast tilt angle α/β(°)	
			3t	3.5t	3.8t	3t	3.5t	3.8t	3t	3.5t	3.8t	3t-S	3t-M	3t-M (P)	3.5t-S	3.5t-M	3.5t-M (P)		3.8t-S
2-stage standard Mast	M200	2000	3000	3500	3800	1570	1620	1680	155	160	160	4404	4454	4574	4704	4754	4874	5134	6/10
	M250	2500	3000	3500	3800	1820	1870	1930	155	160	160	4452	4502	4622	4752	4802	4922	5182	6/10
	M300	3000	3000	3500	3800	2070	2120	2180	155	160	160	4500	4550	4670	4810	4860	4980	5240	6/10
	M330	3300	3000	3500	3800	2220	2270	2330	155	160	160	4529	4579	4699	4842	4892	5012	5272	6/10
	M350	3500	3000	3500	3800	2320	2370	2430	155	160	160	4548	4598	4718	4863	4913	5033	5293	6/10
	M370	3700	3000	3300	3800	2420	2470	2530	155	160	160	4567	4617	4737	4884	4934	5054	5314	6/6
	M400	4000	2850	3150	3700	2620	2670	2730	155	160	160	4647	4697	4817	4968	5018	5138	5398	6/6
	M425	4250	2750	3050	3550	2745	2795	2855	155	160	160	4671	4721	4841	4994	5044	5164	5424	6/6
	M450	4500	2700	3000	3500	2870	2920	2980	155	160	160	4695	4745	4865	5021	5071	5191	5451	6/6
	M500	5000	2200	2450	3000	3120	3170	3230	155	160	160	4743	4793	4913	5074	5124	5244	5504	6/6
2-stage full free mast	ZM200	2000	3000	3500	3800	1570	1620	1680	340	443	503	4432	4482	4602	4728	4778	4898	5158	6/10
	ZM250	2500	3000	3500	3800	1820	1870	1930	590	693	753	4482	4532	4652	4781	4831	4951	5211	6/10
	ZM300	3000	3000	3500	3800	2070	2120	2180	840	943	1003	4532	4582	4702	4835	4885	5005	5265	6/10
	ZM330	3300	3000	3500	3800	2220	2270	2330	990	1093	1153	4564	4614	4734	4868	4918	5038	5298	6/10
	ZM350	3500	3000	3500	3800	2320	2370	2430	1090	1193	1253	4584	4634	4754	4889	4939	5059	5319	6/10
	ZM370	3700	3000	3200	3800	2420	2470	2530	1190	1293	1353	4604	4654	4774	4910	4960	5080	5340	6/6
	ZM400	4000	2850	3200	3700	2620	2670	2730	1390	1493	1553	4682	4732	4852	4990	5040	5160	5420	6/6
	ZM425	4250	2650	2950	3450	2745	2795	2855	1515	1618	1678	4708	4758	4878	5017	5067	5187	5447	6/6
	ZM450	4500	2500	2850	3350	2870	2920	2980	1640	1743	1803	4736	4786	4906	5046	5096	5216	5476	6/6
	ZM500	5000	2100	2450	3000	3120	3170	3230	1890	1993	2053	4790	4840	4960	5102	5152	5272	5532	6/6
3 stage full free mast	ZSM360	3600	2850	3250	3800	1870	1870	1930	640	640	693	4643	4693	4813	4921	4971	5091	5351	6/6
	ZSM400	4000	2750	3100	3700	2020	2020	2055	790	790	843	4684	4734	4854	4962	5012	5132	5392	6/6
	ZSM435	4350	2550	2950	3500	2120	2120	2180	890	890	943	4713	4763	4883	4991	5041	5161	5421	6/6
	ZSM450	4500	2450	2850	3400	2170	2170	2230	940	940	993	4728	4778	4898	5006	5056	5176	5436	6/6
	ZSM470	4700	2400	2800	3300	2230	2230	2295	1000	1000	1053	4746	4796	4916	5024	5074	5194	5454	6/6
	ZSM480	4800	2350	2750	3300	2270	2270	2330	1040	1040	1093	4756	4806	4926	5034	5084	5204	5464	6/6
	ZSM500	5000	2100	2450	3000	2370	2370	2430	1140	1140	1193	4783	4833	4953	5061	5111	5231	5491	6/6
	ZSM540	5400	1950	2350	2900	2470	2470	2555	1240	1240	1293	4813	4863	4983	5091	5141	5261	5521	6/6
	ZSM600	6000	1350	1700	2200	2670	2670	2780	1440	1440	1493	4917	4967	5087	5195	5245	5365	5625	6/6
	ZSM650	6500	950	1300	1800	2870	2870	—	1640	1640	—	4972	5022	5142	5250	5300	5420	—	6/6
ZSM700	7000	1800	2200	—	3045	3045	—	1815	1815	—	5022	5072	5192	5300	5350	5470	—	6/6	

Note: *Indicates the rated load capacity of the front wheel with twin tyres; When the front wheels of 3-3.5t are twin tyres (pneumatic tyres) and twin tyres (solid tyres), the service weight is increased by 140kg and 208kg respectively according to the table data; When the front wheels of 3.8t are twin tyres (pneumatic tyres) and twin tyres (solid tyres), the service weight is increased by 103kg and 251kg respectively according to the table data.
 2-stage full free mast: 3t: When there is no backrest, the free lifting height increases by 477mm; 3.5t-3.8t: When there is no backrest, the free lifting height increases by 407mm.
 3-stage full free mast: 3t: When there is no backrest, the free lifting height increases by 427mm; 3.5-3.8t: When there is no backrest, the free lifting height increases by 407mm.

Lithium Battery Advantages

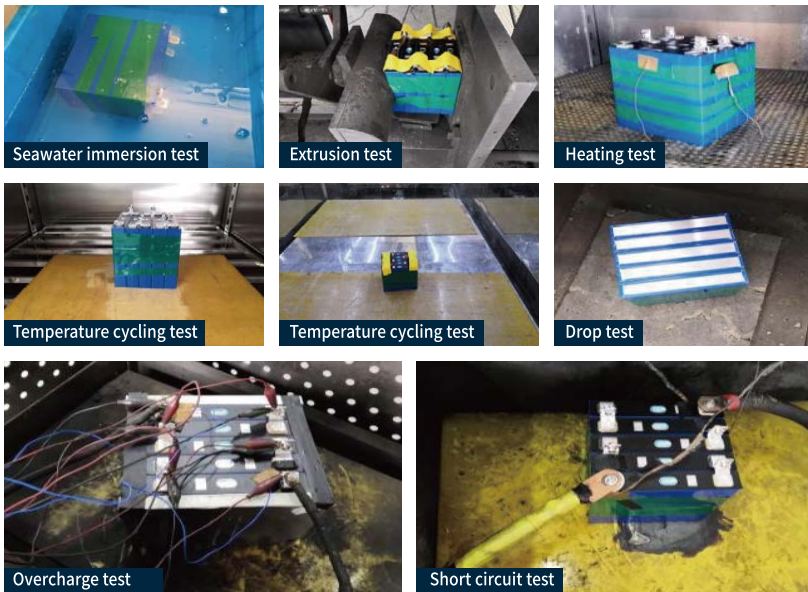

- The truck selects mature and economical square iron phosphate lithium battery core and module used by large numbers of commercial vehicles;
- The module adopts aluminum alloy plate frame, which is firm, light in weight and has good heat dissipation effect;
- Fast charging: fast charging makes truck gapless operation possible, and it can be fully charged in up to one hour;
- High efficiency and safety: The charging and discharging efficiency is up to 98%, and temperature of thermal runaway is over 600 °C;
- Low temperature adaptability: Standard configuration of heating function ensures normal operation of low temperature environment;
- Long service life: Over 75% capacity reserved after 5 years or ten thousand hours;
- Maintenance free: the battery does not need manual maintenance and does not need to add distilled water electrolyte;
- Green and clean: no pollution and zero emission.

HELI smart fleet management system (optional)

Vehicle positioning	Statistical form
Remote diagnosis	Vehicle management
Remote monitoring	Identification recognition (optional)
Maintenance reminder	Weight management (optional)
Battery management	Collision management (optional)



Optional item

Model	S	M
Pneumatic tyre*	●	●
Solid tyre	○	○
Single tyre (front wheel)	●	●
Twin tyre (front wheel)**	○	○
Two piece valve	●	●
Three or four piece valve	○	○
Basic type: 3M lifting height mast	●	●
Other type and other height seriesmast***	○	○
Standard series fork	●	●
Non standard series forks and attachments	○	○
Standard exterior color (blue grey + Heli red)	●	●
Other exterior colors (customized)	○	○
Turning speed limit	○	○
Reversing armrest with horn switch	○	●
Overspeed 5km / h alarm	○	○
Overspeed 8km / h alarm	○	○
Overspeed 10km / h alarm	○	○
Travelling + lifting + tilting + attachment equipped with OPS function (without lowering)	●	●
Full set of OPS functions	○	○
Seat belt switch	○	○
Multi way valve overload	●	●
Dry powder fire extinguisher (0.5kg)	○	○
Dry powder fire extinguisher (2kg)	○	○
Carbon dioxide fire extinguisher (2kg)	○	○
Reversing buzzer	●	●
Reversing Chinese speaker	○	○
No universal key	●	●
With universal key	○	○
Electronic lifting upper buffer	○	○
Central wide-angle rearview mirror	●	●
Both side rear-view mirrors + center wide-angle rear-view mirror	○	○
Reversing radar (4 probes)	○	○
Reversing image (1 Camera + 4 radar probes)	○	○
Semi enclosed seat	●	●
Fully suspended seat	○	○
Instrument panel with 1 USB interface (5V / 1A)	○	●
Steering wheel starts steering	○	○
Synchronous steering	○	○
Steering wheel with handle ball	●	●
Steering wheel without handle ball	○	○
Electric fan	○	○
panel mounted cab (including fan + wiper)	○	○
Heater	○	○
Single cooling air conditioner	○	○
Single cooling air conditioner + heater	○	○
Front windshield (including wiper)	○	○
Rear windshield	○	○
Top windshield (excluding fan)	○	○
50mm increased of overhead guard height	○	○
50mm reduced of overhead guard height	○	○
Overhead guard (with protective net)	○	○
LED rear work light (1)	○	○
Rear LED red / Blue spotlight (1)	○	○
Rear and lateral red / blue bar lights	○	○
Fixed LED flashing warning light	○	●
Fixed LED rotary warning lamp	○	○
Fixed LED rotary buzzer warning light	○	○
Metric thread	●	●
Tilt cylinder jacket	○	○
Steering cylinder jacket	○	○
REMA 320 charging port	●	●
GB charging gun	○	○
Onboard charger	○	○
HELI FICS system	○	○

Note: *●Standard ; ○Optional ;
 Some non-standard options need to be customized. Please consult local sales personnel or product development technicians before purchasing.
 **3-3.8t rear wheel is equipped with solid tyre as standard.
 ***There are restrictions on the type and height of small 2t and 3.8t mast. See the table of mast parameters for details.